

D Series Sensors for Humidity and Temperature Measurement With calibrated dModul

Type DI Room version Optional display

- dynamic MELA® humidity sensing element
- calibrated dModul for humidity and temperature measurement
- with integrated measuring chamber
- easy to install
- operating temperatures up to 60°C

Technical data

Humidity

measuring element	capacitive MELA FE09
output range	0...100 %RH
measuring uncertainty	
40...60 %RH	
(at 23°C / U _B =24 V DC)	±2.5 %RH
10...40 %RH or 60...90 %RH	
(at 23°C / U _B =24 V DC)	±3 %RH
influence of temperature (ref. to 23°C)	typ. ±0.05 %RH/K

Temperature

measuring element	Pt1000
output ranges	0...+50°C -30...+70°C 0...+100°C further ranges on request
measuring uncertainty	
(U _B =24 V DC)	
sensors with active temperature signal	
voltage output 10°C...40°C	±0.25 K
current output 10°C...40°C	±0.4 K
influence of temperature <10°C or >40°C	typ. ±0.01 K/K

Load at current output

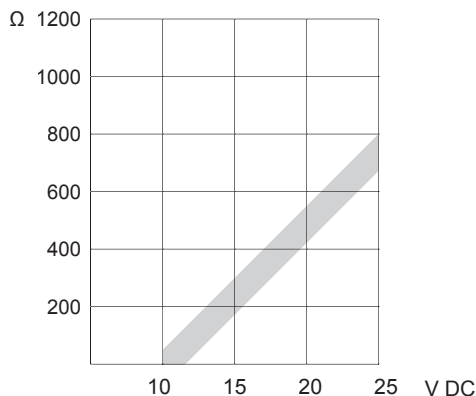

The core part of the D Series is the digital calibrated dModul, which processes the measurement values of relative humidity and temperature individually. The values are compared to the calibration values stored in the dModul and communicated digitally to the transmitter electronics, where they are processed to standardised current and voltage signals.

The integrated measuring chamber of the room version is separated from the electronics. Thus, a good air circulation around the sensing elements is provided.

The housing of the room version has a simple and robust closing mechanism. After mounting the base part, the top which contains the transmitter electronics, can be easily clipped into place and pressed shut without any tool.

Electrical data

outputs	0...1 V 0...10 V 4...20 mA passive temperature outputs on request
---------	--

voltage supply see type survey

consumption of electronics (voltage output) typ. 7 mA

min. load resistance (voltage output) ≥10 kΩ

load R_L (current output)

$$R_L(\Omega) = \frac{\text{voltage supply} - 10 \text{ V}}{0,02 \text{ A}} \pm 50 \Omega$$

electromagnetic compatibility ref. EN 61326-1 and EN 61326-2-3

Options

display 2 lines
3 digits + 1 decimal place
display approx. 21 x 40 mm²
digit height approx. 8 mm

General data

measuring medium	air, pressureless, non-aggressive	
operating temperatures	-30...+60°C	
storage temperatures	-40...+85°C	
connection	wire diameter per connector	connecting terminals max. 1.5 mm ²
	cable diameter	max. 7 mm
	→ surface cable	(5 mm recommended)
	→ in-wall cable	
see: mounting instructions, page 4		
degree of protection	IP 30D	
material of housing	ABS	
color of housing	RAL 9003 / signal white	

Drilling pattern

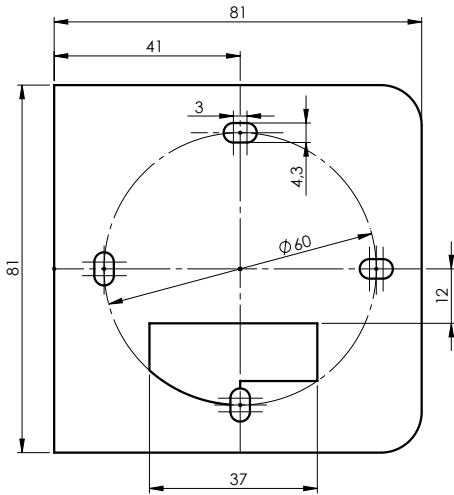

Dimensions

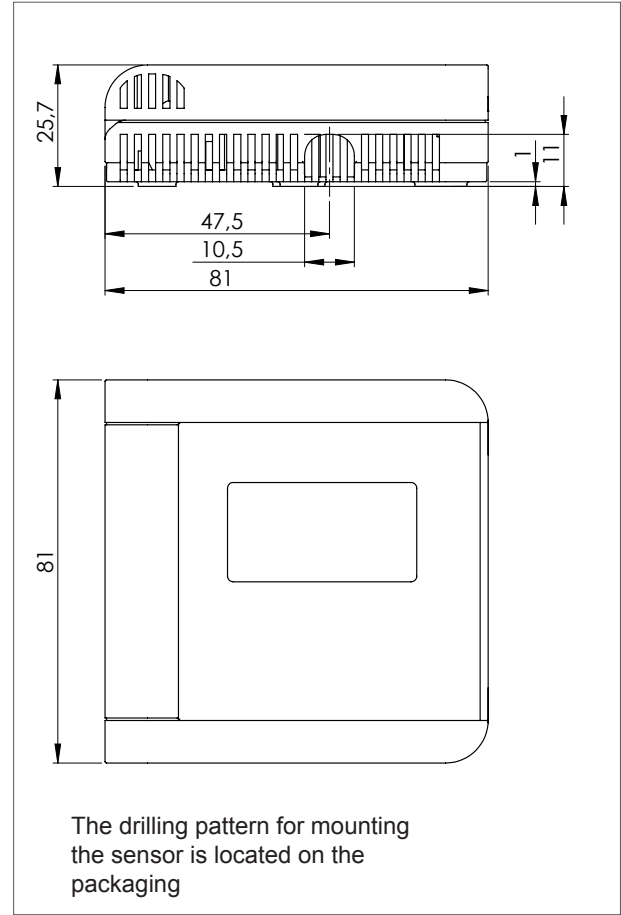

Type survey DIF

Humidity sensor

Type	Housing	Physical variable	Output signal corresponds to	Signal output	Voltage-supply U_B
DIF	Room version optional display	relative humidity	0...100 %RH	0...1 V	6...30 V DC 6...26 V AC
				0...10 V	15...30 V DC 13...26 V AC
				4...20 mA	10...25 V DC

Type survey DIK

Humidity and temperature sensor

Type	Housing	Physical variable	Output signal corresponds to	Signal output	Voltage-supply U_B
DIK	Room version optional display	relative humidity	0...100 %RH	2 x 0...1 V	6...30 V DC 6...26 V AC
		temperature	-30...+70°C 0...+100°C 0...+50°C	2 x 0...10 V	15...30 V DC 13...26 V AC
				2 x 4...20 mA	10...25 V DC

Passive temperature output available on request.

Connection diagrams

DIF 4...20 mA

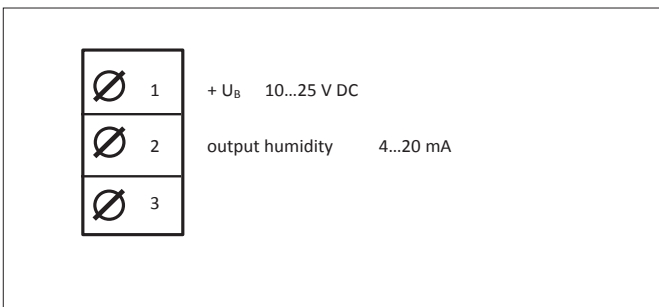

DIK 2 x 4...20 mA

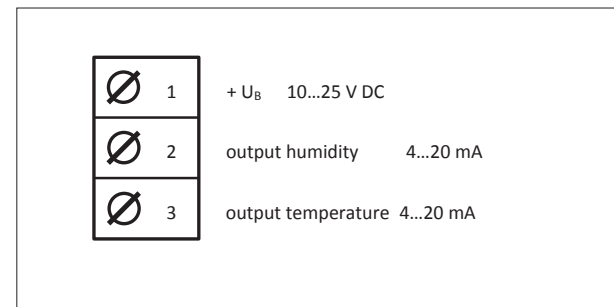

DIF 0...1 V DC

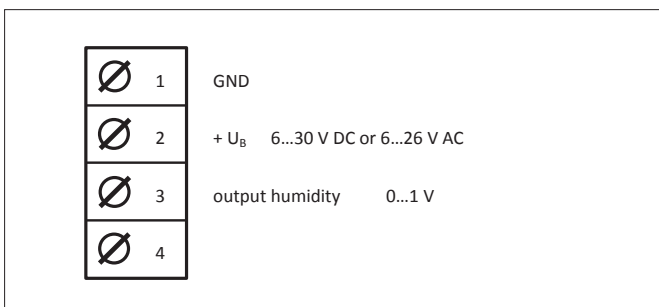

DIK 2 x 0...1 V DC

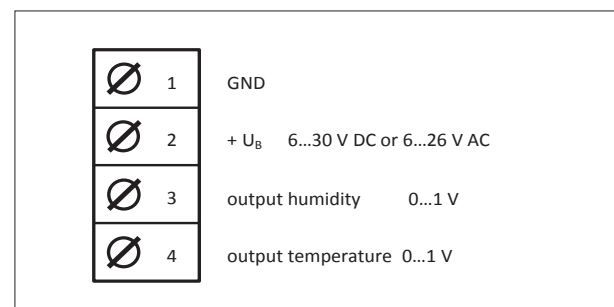

DIF 0...10 V DC

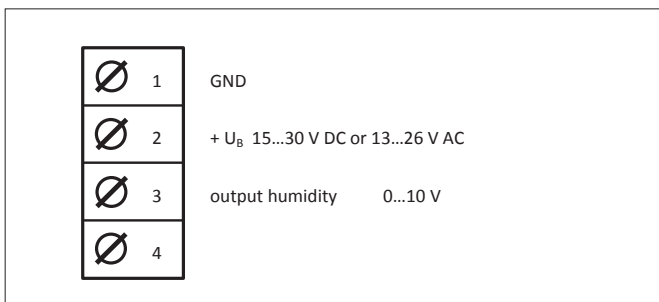

DIK 2 x 0...10 V DC

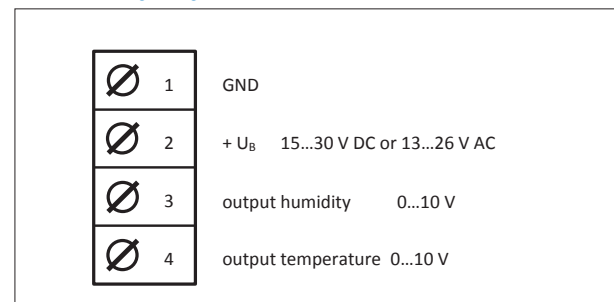

ESD protection advice

The sensors of the D Series contain components, which can be damaged by the effects of electrical fields or by charge equalisation when touched.

The following protective measures must be taken when the housing of the sensor is to be opened for connection:

- Before opening the housing of the sensor, ensure electrical potential equalisation between you and your environment.
- Pay particular attention to ensure that this potential equalisation is maintained while you are working with the opened housing.

Mounting instructions

Position	Install the sensor at a place where characteristic levels of humidity occur. The measuring chamber should be located in streaming air. Avoid installation next to heaters, doors or on outer walls. Avoid places exposed to the sun.
Mounting on a patress	When mounting the sensor on a patress, avoid external air getting onto the measuring elements of the sensor by sealing it appropriately.
Connection to surface and in-wall cable	In order to insert the connection cable, prise the pre-cut part of the housing's base part open. In order to insert a on-wall cable, the bars of the immersed part of the housings side can be removed.
Opening the housing	Apply a flat-headed screwdriver at the top in the locking slot and press inwards until the housing springs open.



Connection	The electrical connection must be carried out by properly qualified personnel only.
	The sensor contains sensitive electrical components. When opening the housing, make sure you comply with the electrostatic discharge precautions.
	Please pay attention to the voltage supply-adapted load (see diagram on page 2) when using sensors with a current output.
	Lines to and from the sensor must not be installed parallel to strong electromagnetical fields.
	If there is any chance of an electrical surge, please install surge protection devices.

User instructions

Dew formation	Dew formation does not damage the sensor, although measurement readings are corrupted until all moisture on and around the sensing element has dried up completely.
Damaging influences	Depending on type and concentration, agents that are corrosive and contain solvents, can result in faulty measurements and can cause the sensor to break down. Substances deposited on the sensor (e. g. resin aerosols, lacuer aerosols, smoke deposits etc.) are damaging as they eventually form a water-repellent film.

This information is based on current knowledge and is intended to provide details of our products and their possible applications. It does not, therefore, act as a guarantee of specific properties of the products described or of their suitability for a particular application. It is our experience that the equipment may be used across a broad spectrum of applications under the most varied conditions and loads. We cannot appraise every individual case. Purchasers and/or users are responsible for checking the equipment for suitability for any particular application. Any existing industrial rights of protection must be observed. The quality of our products is guaranteed under our General Conditions of Sale. Data sheet DI. Issue November 2013. Subject to modifications.

Galltec

Mess- und Regeltechnik GmbH
Boschstr. 4
71149 Bondorf
Tel. +49 (0)7457-9453-0
Fax +49 (0)7457-3758
E-Mail: sensoren@galltec.de

MELA

Sensortechnik GmbH
Raasdorfer Str. 18
07987 Mohlsdorf-Teichwolframsdorf
Tel. +49 (0)3661-62704-0
Fax +49 (0)3661-62704-20
E-Mail: mela@melasensor.de